



UNIVERSITAS
GADJAH MADA



Developing an LADM-compliant Mobile Data Collector for Accelerating Participatory Cadastral Mapping and Registration

Key words: para surveyor, land mobile data collector, participatory cadastral mapping, LADM

Trias ADITYA, I Ketut Ary SUCAYA, Fajar Adi NUGROHO and Hanhan Lukman SYAHID, Dany LAKSONO
Indonesia

Universitas Gadjah Mada, Yogyakarta, Indonesia &
Ministry of Agrarian & Spatial Plan (ATR/BPN)

ATRBNP.GO.ID

UGM.AC.ID

LOCALLY ROOTED, GLOBALLY RESPECTED

LA Product Requirements

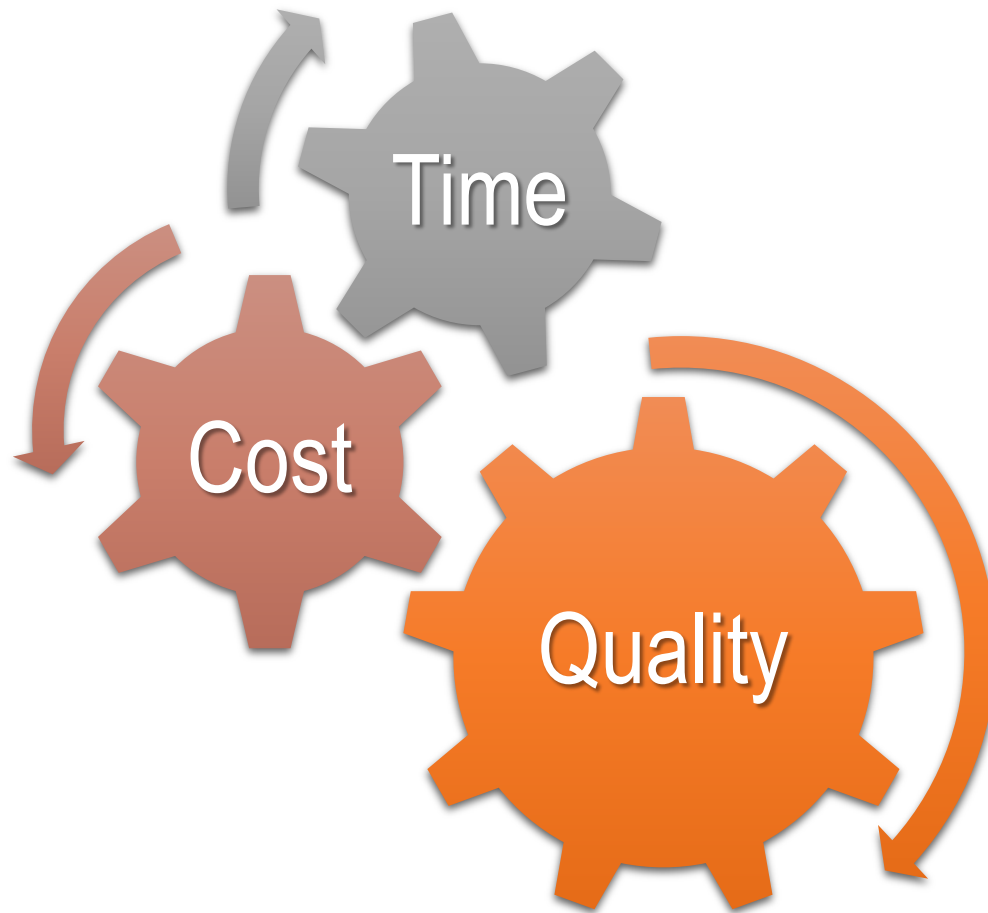

Goals:

Cutting off **time** and **procedures** to produce correct information about **land boundaries on the field** (represented as spatial data), **persons own/use the property** (verified through person ID), and underlying documents and verifications for:

- (1) **First-titling registration and**
- (2) **Cadastral incremental improvements**

ATRBP.N.GO.ID

Challenges



2024

137 mio.
Titled &
Validated
100%

Increasing Quantity (of Land Titles)
Improving Quality (of Cadastral Records)

191.2 mio ha
74,957 villages
513 districts/cities
34 Provinces
App. 135 mio. Land parcels

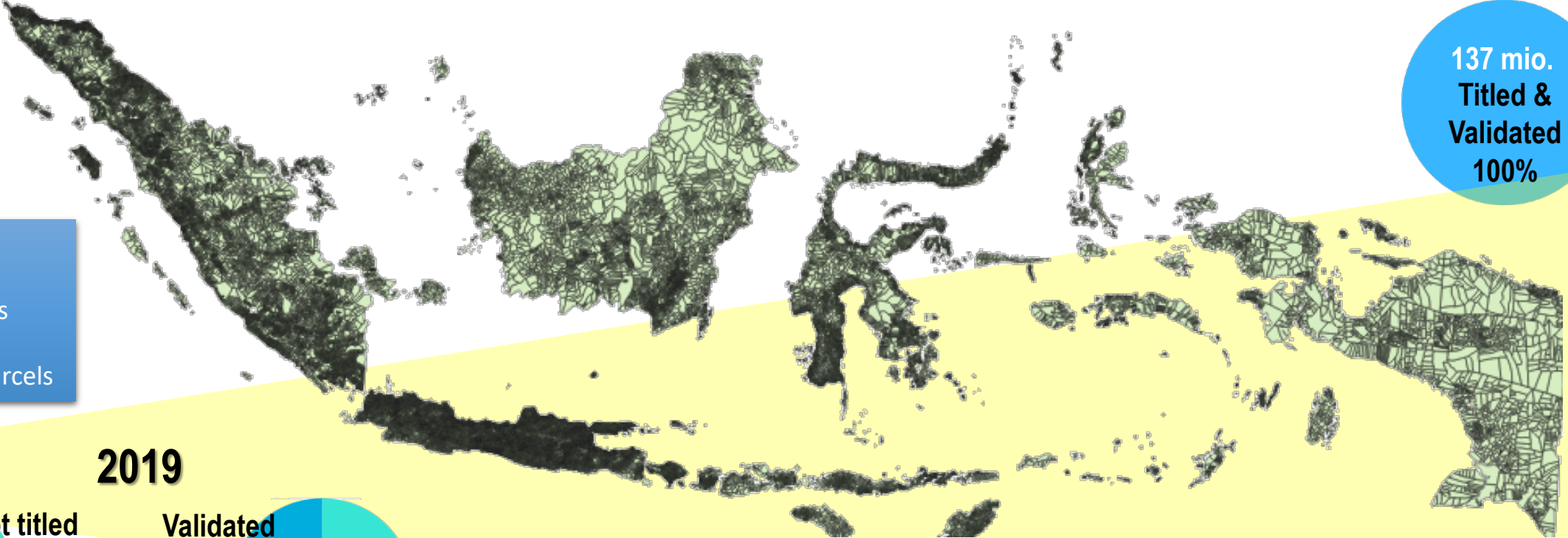

2019

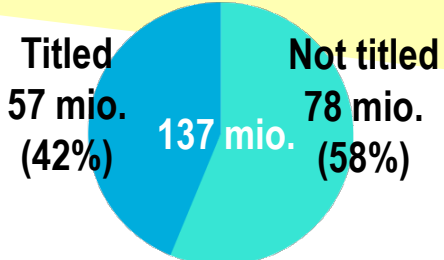

Number of land parcels

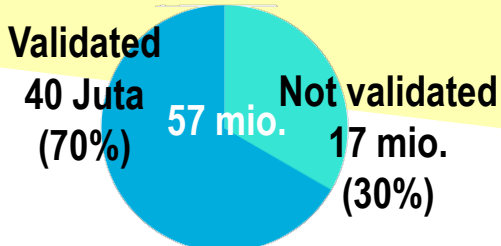

Number of land titles

ATRBPN.GO.ID

Paper & Electronic Records



No. Seri:	Pilih No Seri	<input type="text"/>	<input type="button" value="X"/>	<input type="button" value="v"/>
Propinsi:	Jawa Tengah			
Kabupaten/Kota:	SURAKARTA			
Kecamatan:	LAWEYAN			
Desa/Kelurahan:	PURWOSARI			
DI. 307:	775	/	1967	10/07/1967
DI. 208:	130	/	1967	10/07/1967
Nomor Hak:	11020107100189			
Asal Hak:	Konversi			
Alas Hak:	<input type="text"/>			
DI. 202:	Nomor	/	Tahun	Tanggal
Surat keputusan:	Nomor	Tanggal		
No. Permohonan:	Nomor	/	Tahun	Tanggal

NIB					
NIB	Luas M2	Desa/Kelurahan	PP	TT	SS
11020107.00660	823	PURWOSARI	<input checked="" type="checkbox"/>	<input type="checkbox"/>	<input type="checkbox"/>
Surat ukur					
Nomor	Desa				
00713/2008	PURWOSARI				
Pemilik pertama					
NIK	Nama	Tempat, Tgl Lahir			
	MARTOMIJONO ALIAS MIJO	-, 01/01/1900			
Penandatanganan Pembukuan					
Tgl. Pembukuan:	10/07/1967				
Jabatan:	<input type="checkbox"/> An. Kepala Kantor				
Nama:	R. SOEGONO				

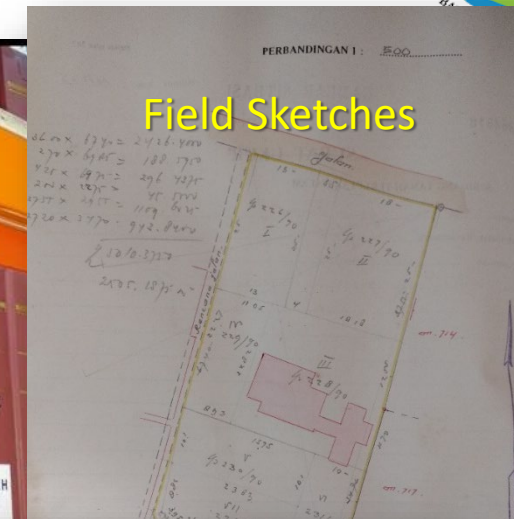

Field Sketches



Letter Measurements

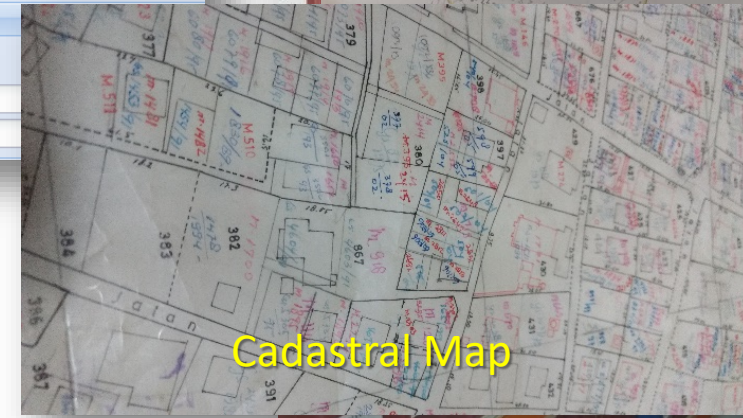

Cadastral Map



Land Registry

Issues hindering completeness & reliability

- ✓ Sporadic activities
- ✓ Incomplete digitalization
- ✓ Paper & electronic records synchronization

Remedy to the Challenges?



participation

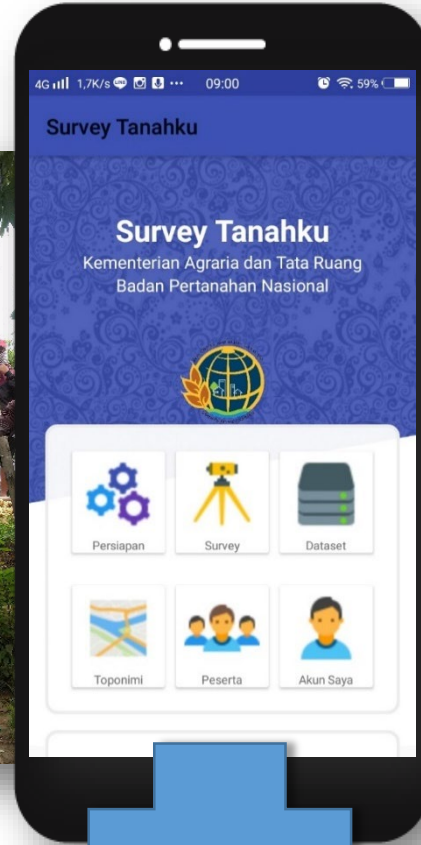

Smart data collection

ATRBPNGO.ID

Data Collector

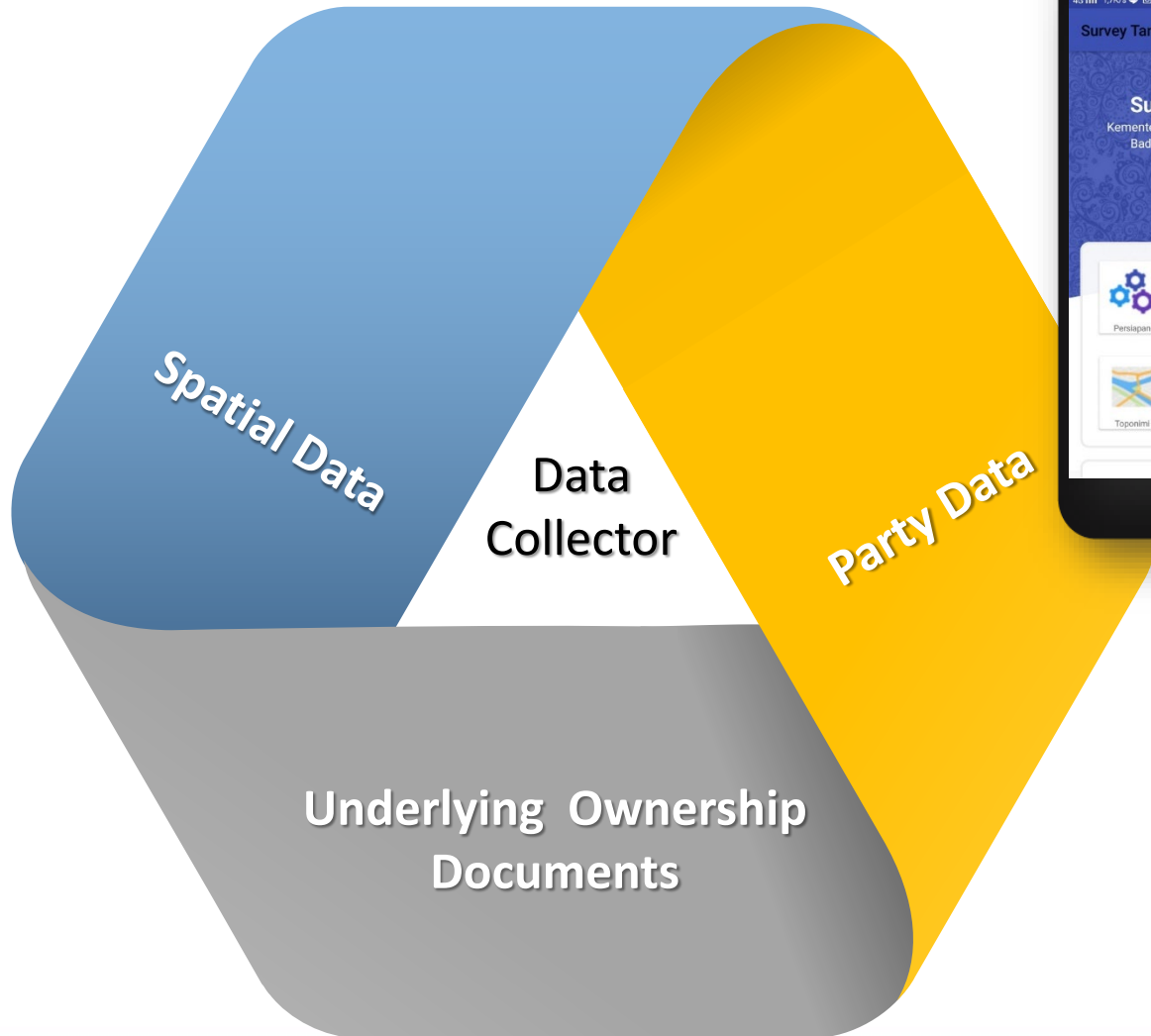

Goals:

Cutting off **time** and **procedures** to produce correct information about **land boundaries on the field** (represented as spatial data), **persons own/use the property** (verified through person ID), and underlying documents and verifications for:

First-titling registration and Cadastral data quality improvement

ATRBPN.GO.ID

Work objectives



Developing a Mobile Data Collector to Enable Government Surveyor & **Para Surveyors** To Collect & Upload Party, Underlying Right & Spatial Data for Land Registration Purposes



that complies to **LADM** standard (ISO 19152:2012)

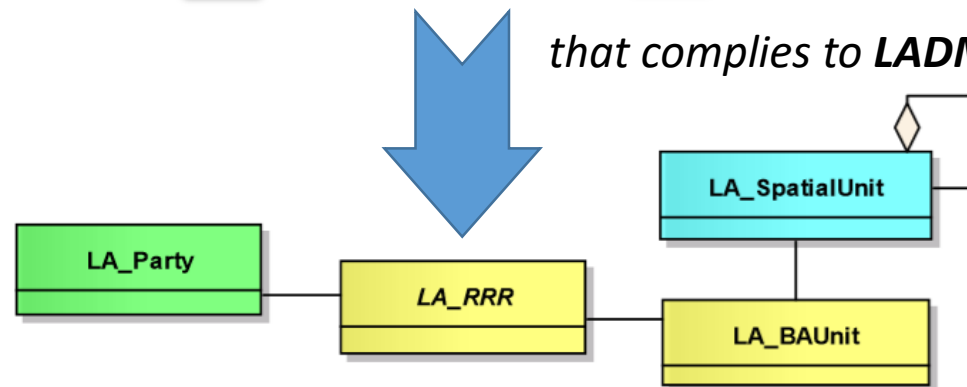

ICS > 35 > 35.240 > 35.240.70

ISO 19152:2012

Geographic information – Land Administration Domain Model (LADM)

SUSTAINABLE DEVELOPMENT GOALS

This standard contributes to the following Sustainable Development Goals:

1 2 11 14 15

ATRBPN.GO.ID

Who are parasurveyors?



UNIVERSITAS
GADJAH MADA



Legal data collection



Para suveyor briefing



The Young Volunteer



GPS measurement

Local leaders, young activists in the village specially trained and prepared by local land offices and partners for facilitating participatory boundary & legal/party data collection {**assigned officially** by local land office and **a valid account** to access the app}

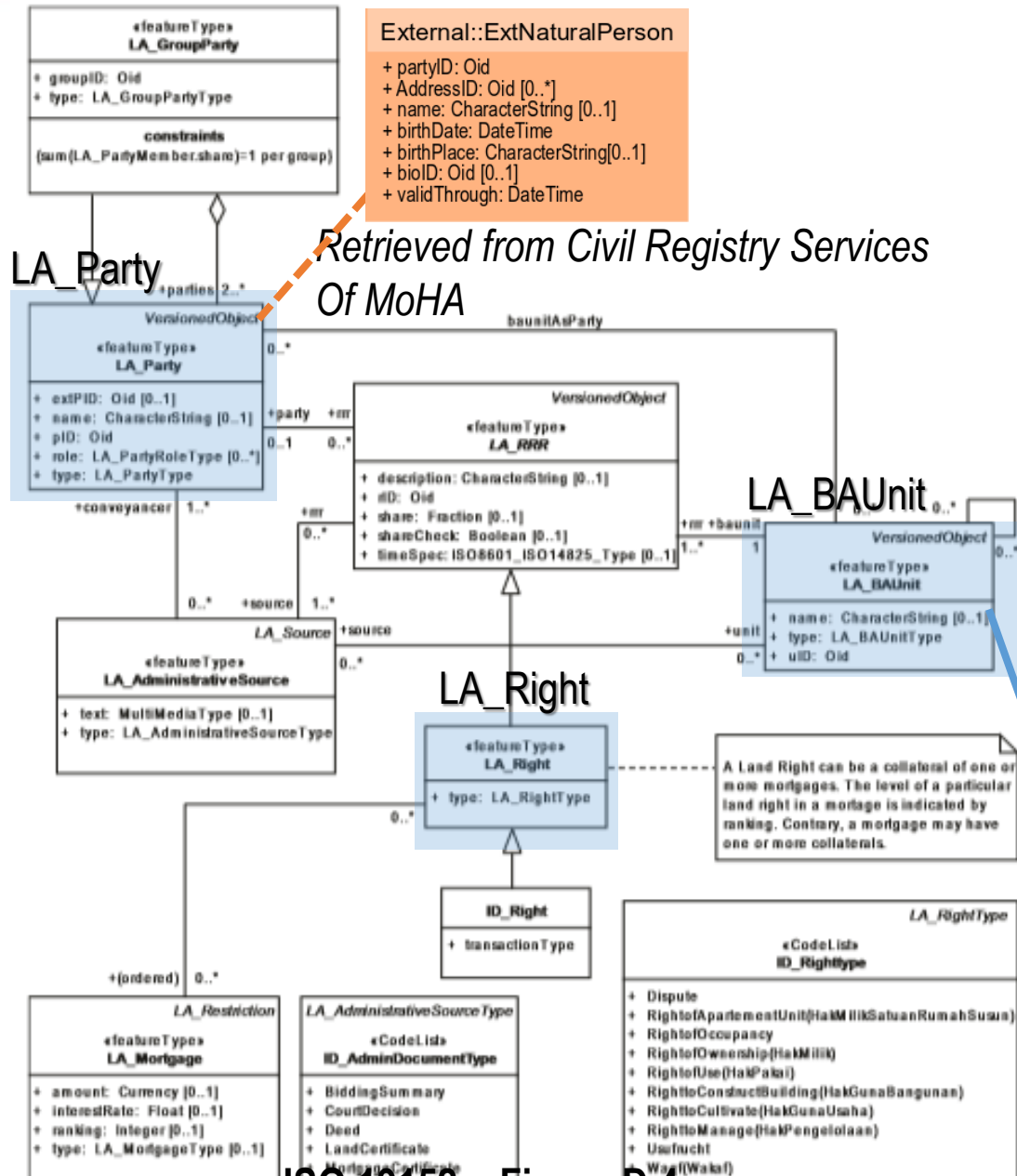

ISO 19152 – Figure D.4

LA_Surveying Package *Digitized from the field*

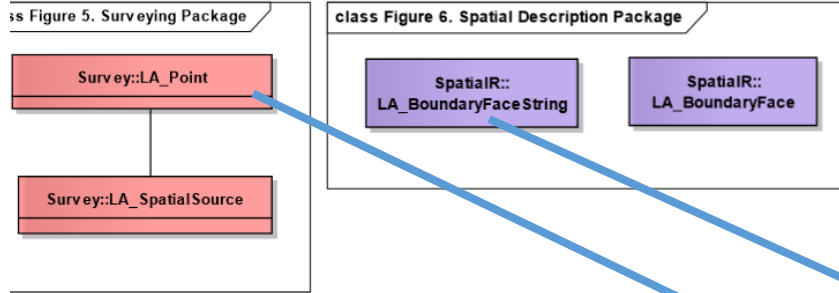

Submitted via Mobile App for Office Inspection

LA_SpatialUnit

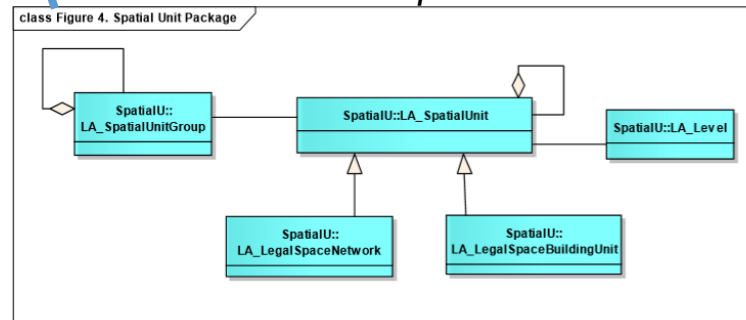

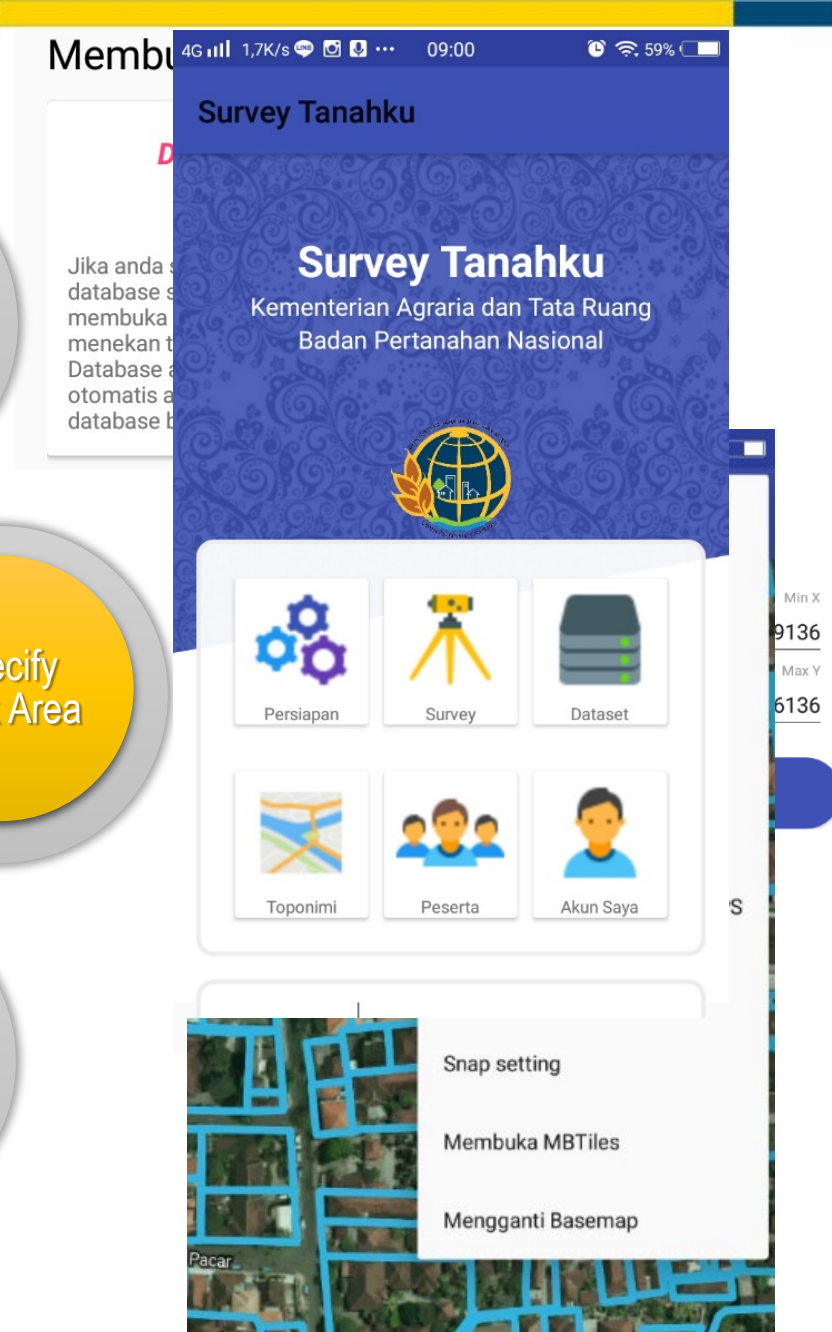

The results of
uploaded
databases

Data Storage



	KODE	KANTOR	WILAYAH	TIPEDOKUMENID	JUMLAHBIDANG	TANDATERIMA	PROGRAM	RSILPARTISIPATIF	JENISHAK	VOMO
4300	2209	Kantor Pertanahan Kota Denpasar	SUMERTA KAUH	PKJ	214	6/2019		3889	-	-
4301	2209	Kantor Pertanahan Kota Denpasar	SUMERTA KAUH	PKJ	213	5/2019		3614	-	-
4302	2209	Kantor Pertanahan Kota Denpasar	SUMERTA KAUH	PKJ	213	5/2019		3615	-	-
4303	2209	Kantor Pertanahan Kota Denpasar	SUMERTA KAUH	PKJ	213	5/2019		3612	-	-
4304	2209	Kantor Pertanahan Kota Denpasar	SUMERTA KAUH	PKJ	213	5/2019		3613	-	-
4305	2209	Kantor Pertanahan Kota Denpasar	SUMERTA KAUH	PKJ	213	5/2019		3643	-	-
4306	2209	Kantor Pertanahan Kota Denpasar	SUMERTA KAUH	PKJ	213	5/2019		3644	-	-
4307	2209	Kantor Pertanahan Kota Denpasar	SUMERTA KAUH	PKJ	213	5/2019		3642	-	-
4308	2209	Kantor Pertanahan Kota Denpasar	SESETAN	PKJ	1	3/2019		3581	-	-
4309	2209	Kantor Pertanahan Kota Denpasar	SUMERTA KAUH	PKJ	213	5/2019		3640	-	-
4310	2209	Kantor Pertanahan Kota Denpasar	SUMERTA KAUH	PKJ	213	5/2019		3641	-	-
4311	2209	Kantor Pertanahan Kota Denpasar	SUMERTA KAUH	PKJ	213	5/2019		3637	-	-
4312	2209	Kantor Pertanahan Kota Denpasar	SUMERTA KAUH	PKJ	213	5/2019		3639	-	-
4313	2209	Kantor Pertanahan Kota Denpasar	SUMERTA KAUH	PKJ	213	5/2019		3635	-	-
4314	2209	Kantor Pertanahan Kota Denpasar	SUMERTA KAUH	PKJ	213	5/2019		3636	-	-
4315	2209	Kantor Pertanahan Kota Denpasar	SUMERTA KAUH	PKJ	213	5/2019		3633	-	-
4316	2209	Kantor Pertanahan Kota Denpasar	SUMERTA KAUH	PKJ	213	5/2019		3634	-	-
4317	2209	Kantor Pertanahan Kota Denpasar	SUMERTA KAUH	PKJ	214	6/2019		3813	-	-
4318	2209	Kantor Pertanahan Kota Denpasar	SUMERTA KAUH	PKJ	214	6/2019		3812	-	-
4319	2209	Kantor Pertanahan Kota Denpasar	SUMERTA KAUH	PKJ	214	6/2019		3815	-	-

Dashboard User Interfaces

LA Registrar/Manager Dashboard
for verifying data
collected from govt.
surveyors & para
surveyors

Pengumpulan Data Fisik
Kabupaten Puncak Jaya



Beranda

Pengolahan Data

Pengukuran Pemetaan

Klarifikasi

Kluster 3.3

Penerbitan

Info Peta

Surveyor

Monitoring Terkini

Administrasi

TANDATERIMA PROSES

Pencarian Tanda Terima

Tipe Dokumen : Pilih tipe dokumen...

Nama Proyek : Pilih program...

Desa/Kelurahan : Pilih desa / kelurahan...

Nomor : Tahun : 2019

Cari

No	Tipe	Nomor	Tahun	Tanggal Terima	Kegiatan	Kecamatan	Desa	Bidang	PE	GU	Pengirim
1	Peta Kerja	105	2019	03/09/2019		Banjar	Sukamaju	1			
2	Peta Kerja	104	2019	03/09/2019		Banjar	Sukamaju	2			INDAH RATNA FURI
3	Peta Kerja	103	2019	29/08/2019		Alalak	Handil Bakti	5			
4	Peta Kerja	102	2019	20/08/2019		Alalak	Handil Bakti	1			INDAH RATNA FURI
5	Peta Kerja	101	2019	19/08/2019		Banjar	Sukamaju	1			
6	Peta	100	2019	19/08/2019		Banjar	Sukamaju	2			

The submitted
database package
From the field

Dashboard User Interfaces

LA Registrar/Manager
Dashboard
for verifying data
collected from govt.
surveyors & para
surveyors

LA_SpatialUnit

PERMENAS SAPARI

TANDATERIMA PROSES

PETA FILE

Tanda Terima tidak memiliki gambar ukur !!!

Buat Gambar Ukur

Dokumen Tanda Terima Nomor 98 / 2019

No	Type	Keterangan	Edit
1	Badan Hukum	Party	PT. Archo
2	Surat Pernyataan Pengusutan	Occupancy Letter	10/01/19
3	SPPT	Taxation	5787567

Previous 1 Next

Terima Berkas Noname

Informasi Dokumen

Silahkan klik edit pada dokumen

Concluding Remarks from Work in Progress

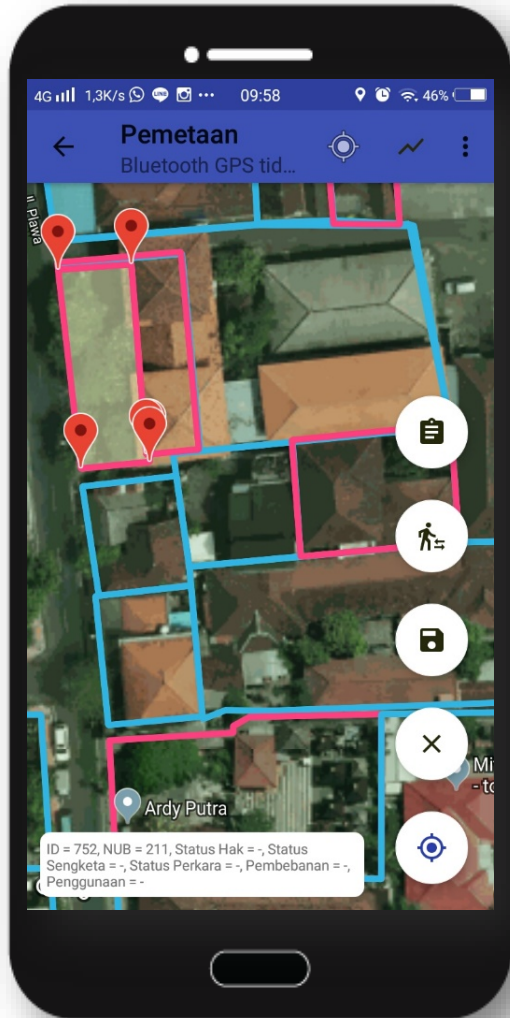

Effectiveness

- **An LADM-crafted Mobile App fits to Enable Efficient Cadastral Data Collection & Improvement that procedurally demanding**
Para surveyors & Surveyors act as **trusted intermediaries** in **Party, Right, Spatial** data at once

Efficiency

- **Boundary determination/identification for first land titling projects & cadastral data improvements can be documented efficiently to cut time and procedure in LA**
The LADM-conformant databases in Indonesia National LIS can be improved with facilitated field data records gathered through the Mobile App

Extendibility

- **Sensors in the App (GNSS Accurate Survey + Photo Capture + Video + Fingerprint Reader) will improve the collection of Administrative Documents in LADM**
Efficiently can be delivered but the real challenges include new institutional arrangements & legal umbrella for applying the solution



UNIVERSITAS GADJAH MADA

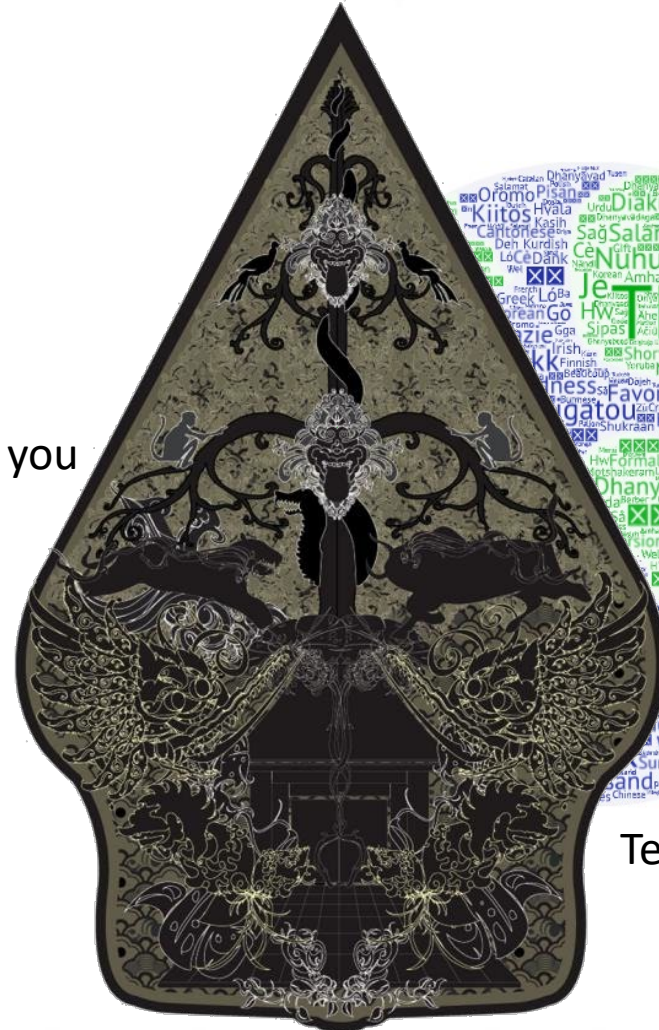

Thank you



Terima kasih



LOCALLY ROOTED, GLOBALLY RESPECTED

ATRBN.GO.ID

CP: triasaditya@ugm.ac.id

UGM.AC.ID