

# A Geometric-Topologic Exemplification for 3D Cadastre

Edward Eric DUNCAN and Bernad Chengxi SIEW, Malaysia

**Key words:** 3DTM, 3D cadastre, volume parcels, spatial data models

## SUMMARY

Professional surveyors all over the world are the repository of locational geoinformation data, in the form of either implicit or explicit geometry formats as defined by the Open Geospatial Consortium (OGC). Two dimensional (2D) cadastre data is not difficult to realise, for 3D data acquisition and modelling, this is a challenge. Different three-dimensional (3D) spatial data models exist for different purposes and applications, therefore, the need to select a single spatial data model for all applications is still difficult to realise. This paper outlines the requirements for a unified spatial data model for 3D cadastre capable of representing volume parcels for man-made objects such as a block of flats in a city centre. Microsoft visual C++ 2008 programming language, OpenGL and Qt libraries were used to develop an application for 3D cadastre. The algorithm and modelling techniques are discussed and an implementation for 3D cadastre highlighted. The concepts highlighted are significant for 3D cadastre in an urban environment due to the multiplicity of ownership for the same parcel of land. The 3D Tetrahedralization Model (3DTM) is significant and can be adopted as the geometric representation for 3D cadastre. 3DTM is a single spatial data model for all man-made constructions; this can advance the development of a fully operational 3D GIS application software. The model can also be used for facility management and change detection. Further work will research into indoor navigation for 3D cadastre.

# A Geometric-Topologic Exemplification for 3D Cadastre

Edward Eric DUNCAN and Bernad Chengxi SIEW, Malaysia

## 1. INTRODUCTION

Cadastre is the term used to describe the process of acquisition and ultimate ownership of a land parcel on the surface of the Earth. The land parcel or marine parcel can be within the extents of a continent, country, region, district and sector. Dale and Mclaughlin (1988) described land as the primary resource for wealth creation. Land here refers to both land and sea surface; this can be above, on and below these surfaces. The economic and social well-being of a populace depends on the activities undertaken on land. Property or land administration of any country needs to be effective and secured, hence countries all over the world require accurate demarcation of land parcels to determine location and extent of land parcels, establish accurate land ownership and ensure the proper documentation of land related data. Subsequent documentation of a land parcel is guaranteed to serve as security to land ownership thus serving as a vehicle for social and economic change. The cadastre also serves as the supporting tool for land policies, fiscal policies and agricultural policies. Current European multipurpose cadastral systems are intended for either taxation or for title registration for planning purposes. Common denominators in these types of cadastre are the unambiguous identification of spatial property and a standardised numbering schema that is uniformly referenced. This identification method allows different vertical application areas, such as taxation, legal, and planning offices, to refer to the same real property. Thus, when the fiscal cadastre promulgates a change on the tax record of a specific parcel, a GIS map shows the tax information changes on the same parcel for the legal cadastre. Land parcels in most cities belong to multiple owners as the city parcel will have space above and below the surface which cannot be shown on a 2D map, hence the need for 3D multipurpose cadastre. Cadastre 2014 (Lemmen et. al, 2009), is geared towards completing a framework for multipurpose cadastre which aims at improving relationships between man and land, role of government and its agencies to land, technology in relation to multipurpose cadastre, data acquisition methods and the role of professional surveyors and private individuals in multipurpose cadastral systems. Most cadastral registration systems are parcel based systems, which are 2D, the Swedish cadastre (Ericsson, 2008), the Danish (Jorgen, 2004) cadastre and the catasto-cumini cadastre of Italy (ESRI, 2005). Most of these cadastres use 2D GIS with aerial photographs and satellite imagery to build their land database. Currently 2D cadastre mapping is practiced in Malaysia which provides vital land and property information like ownership of the parcels for most parts of the country (refer Table 1).

**Table 1. Cadastre types of some countries**

COUNTRY	CADASTRE TYPE	TOOLS
NETHERLANDS (Lemmen, 2012)	2D and 3D	USER DEFINED (ELAN +3D PDF)
SWEDEN Ericsson, (1995, 2008) and Astrand, (2010)	2D and 3D	USER DEFINED (ArcCadastre)
DENMARK Skrubbeltrang, (2004)	2D	GIS
ITALY ESRI (2005)	2D	GIS / REMOTE SENSING
NORTHERN IRELAND ESRI (2005)	2D	GIS
Malaysia (Abdul Rahman et. al., 2011)	2D	MapInfo

This system of cadastral information has served most of the users need for decades. However, in the very near future, 2D information may no longer be able to serve the community, especially in more complex situations such as condominiums and office complexes in large cities or towns such as Kuala Lumpur in Malaysia. One way to deal with this situation is by having a more advanced cadastral system. Hence, the need to extend the 2D cadastre system into a system that is able to deal with various aspects of cadastre such as 3D cadastre (Stoter, 2004), 3D marine cadastre, and 3D city models (Abdul Rahman et. al., 2005). Several drawbacks from existing cadastre system such as building foot or roof prints hardly available within cadastre parcels, strata information not linked to the stratum, real 3D buildings with proper and real textures are not available within the parcel lots and obviously the associated database not available. A new version of cadastre, i.e. the MPC could provide the relevant information to various agencies and individuals in the country. Abdul Rahman et. al., (2011) has also enumerated the need for MPC to embed 3D city models and underground structures. Current cadastres has employed CAD software, GIS and database in creating various cadastres but has not been able to sustain a fully developed system, hence user defined algorithms are required to expand the multipurpose cadastre to consider the above and below surface parcels. This paper seeks to present a spatial data model for 3D cadastre, the design and implementation of 3D volume parcels is presented within a graphical user interface

(GUI). The 3D geometric modelling part for representing 3D objects, above, on and below the surface is significant for most buildings in any city centre. Section 2 presents a review of the data capture, processing and representation of 3D data from a surveyor's perspective. Section 3 discusses spatial data models, Section 4, the unified spatial data model and implementation for 3D cadastre. Section 5 is the exemplification and Section 6, the concluding remarks and further research for this paper.

## 2. SPATIAL DATA MODELLING

2D cadastre represents the land parcel as a polygon with edges and nodes, this was easy to realise using various application software such as AutoCAD, ArcGIS and a relational database such as Microsoft excel, access, Oracle and others. The concept for 3D volumes has been put forward (Abdul Rahman et. al., 2011 and Lemmen, 2012). Several drawbacks from existing cadastre system have been enumerated in Section 1. OGC (2012) now defines LoD 0 as including building foot or roof prints. Currently due to the multiplicity of ownership for a specific land parcel a spatial data model is required for the exemplification of volumetric based parcels a review of current 3D spatial data models (refer Table 2) and a selection of one enhanced unified spatial data model for most applications may be the unique model for 3D GIS.

**Table 2 shows some previous spatial data models.**

Spatial Model	Geometries	Limitations	Applications
3D FDS	Node, edge, arc, face	2D GIS as topology was easier to implement	2D GIS
3D TIN	TNode, Tedge, Tpolygon and Tsolid	Surface and geology	2D/3D hybrid: Surface and subsurface boreholes
3D TEN	Node, arc, Triangle, Tetrahedron	Geology and pollution clouds	Geology and urban applications
SSM	Face and body	No arc in the model	Web and visualisation
UDM	Node and face(triangles)	City modelling	Tetrahedrons not applied, urban management
OODM-ISDM	Node, arc, Triangle, Tetrahedron	TIN and tetrahedron part not achieved. City modelling and geology	City objects and drill holes
E <sup>2</sup> GIS	Node, arc, Triangle	No application model	Engineering (tunnels) and Geology
Cell Complex	Point, line, face volume	Large data	Geoscience
Somas	Node relationships	Implementation in a database not possible	Urban management
Rosa and Cervelle	Node, edge, arc, face and volume	Simple geographical objects	Model cavities and holes

Surface 3D objects in the case of 3D city models have been studied by various researchers using the vector approach (Molenaar, 1990; Abdul Rahman, 2000; Zlatanova, 2000; Coors, 2003). 3D data models such as the tetrahedral network (TEN) (Pilouk, 1996) the constrained

/

tetrahedral network (TEN) (Penninga and Oosterom, 2008), the Object Oriented Data Model (OODM) (Wang, 2006), Urban Data Model (UDM) (Coors, 2003) and the Simplicial Simplex Model (SSM) (Zlatanova, 2000) approaches have been used for 3D city modelling.

Surface and subsurface unified models have been studied by researchers: Abdul Rahman and Pilouk, 2008; Wang, 2006; Breunig and Zlatanova, 2006; Zhou et. al., 2008. The principle behind their research was enhanced forms of 3D FDS for 3D objects using 3D spatial data for objects above the surface and below the subsurface. The 3D FDS (Molenaar, 1990) was proposed for 2D GIS, but this has been adopted and made applicable by researchers for 3D GIS. The model has the point, line, surface and body as the entity object from the basic geometry of the node with topological relations of is in, is on, left and right.

Researches for subsurface 3D models were aimed at modelling the natural subsurface: Abdul Rahman (2000) used the 3D TIN for drill hole locations. This idea was extended by Wang (2006) to include city modelling. Breunig et. al., (2001) carried out extensive research on geological bodies (GeoToolKit) using the TEN model. Zhou et. al., (2008) also used the cell complex and implemented the model for geology. The OO3D-ISDM spatial data model (Wang, 2006) was used for the integration of city objects and drill hole data based on the concept of 3D TIN. Wu and Shi, (2004) proposed a spatial data model based on G-GTP and E-GTP the generalized tri-prism (GTP) for geosciences applications, these models uses the concept of 3D TIN in its implementations. The cell complex which is an enhanced concept from 3D TIN was applied as an integrated model in the area of city objects and geology (Pigot, 1992 and Zhou *et. al.*, 2008). Researchers have enumerated the need to integrate man-made objects for both the surface and subsurface (Emgard and Zlatanova 2008; Zhou et. al., 2008; Ledoux and Gold, 2008; Zlatanova, 2008; Gold, 2008). Concepts from current data models (Abdul Rahman and Pilouk, 2008; Wang, 2006; Wu and Shi, 2004) which investigated models for above, on and below surface objects basically for geology, can be extended to include man-made objects for the subsurface. Most of the spatial models investigated showed the TIN and 3D TIN in a hybrid approach by integrating TIN with other 3D representations. Abdul Rahman (2000) used the 3D TIN in a 2D and 3D TIN hybrid approach to represent 3D simple buildings with terrain and borehole representation for the subsurface. Pilouk (1996) used the 3D TEN (TIN) to represent geological features. Concepts for volume parcels for 3D cadastre have been presented by Abdul Rahman et. al., (2012) and Lemmen (2012). The quest for a unified spatial data model still under research. This research further enhances these concepts and exploits the concept for 3D cadastre and implements these concepts with Level of Detail (LoD) concepts for texturing buildings in 3D cadastre.

### 3. 3D DATA CAPTURE AND RECONSTRUCTION

Surveyors or Geoinformation specialists are usually concerned with the measurement and collection of geospatial information of natural or artificial features. Equipment used for data collection will vary according to speed, cost, reliability and accuracy. Processing of the geospatial data also depends on equipment, software and database requirements. The Surveyor is in charge of the geometric part of the land parcel or land lot demarcation, hitherto,

/

this was not a challenge because cadastre parcels were polygonal. Currently, for 3D geometric cadastre presentation, data collection and 3D modelling is a challenge. Spatial objects are features that can be located on the surface of the Earth by way of geographic coordinates such as latitudes and longitudes or by way of national coordinates which are in Northings (X) and Eastings (Y). The addition of height in relation to terrain is 2.5D and the relation from the terrain to measurements on a building is 3D. Spatial representations are unique, since ideally no coordinate pair can represent two different features on the surface of the Earth. 2D GIS is a knowledge based tool through topology which establishes knowledge between the various geometric primitives such as points (or nodes or vertices), lines (arcs or segments or edges) and polygons (areas or faces) together with their semantic properties. 2D GIS has several limitations such as the visualization of feature objects as points, lines and polygons, difficulty in interpreting some 2D maps due to hidden features, difficulty in visualizing utility networks due to inadequate information on height (Abdul Rahman et.al., 2012) and 2D map generalization. Hence, most 2D maps are inaccurate and can also not be relied on for 2D cadastre, this stalls developments in most city centres, where these 2D cadastre maps introduces a high level of complexities. The visualisation of feature objects within a digital environment representing reality is the basis of 3D GIS. With the introduction of height (Z) above sea level, features can be realised in 3D, users could also visualise 2.5D in relation to the Earth's surface, this is the digital terrain model (DTM). 3D data can be obtained from varied sources among these are Computer Aided Design (CAD) drawings where the basic geometric element, the node can be extracted, this can be the national coordinates or geographic coordinates as defined for a specific country. Orthophotos and orthoimagery from digital photogrammetry or remote sensing respectively can also be used in demarcating cadastre parcels, in this case the basic geometry is the voxel for the raster environment.

According to OGC (2012), the spatial model of city objects are based on ISO 19107 standard which represents 3D geometry according to the b-rep of Foley et. al., (1995). CityGML avoids the repetition of faces with topology being maintained, however the problem of leaving holes may persist and the concept of a composed object without holes necessary to achieve a model. CityGML has made topology optional but currently, a major issue in 3D GIS. In this research, directional adjacency is considered to exploit the concept of above, beside and below adjacency relations. CityGML supports the modelling of underground buildings and tunnels but the integration of the above, on and below objects has not been achieved. Standards such as CityGML, GeoSciML and Industry Foundation Classes (IFC) has been developed for 3D spatial artificial and natural features above and below the Earth's surface, these features have not been integrated due to challenges in geometric, topologic and semantic heterogeneities. However the integration of these standards is under consideration by OGC (2013).

3D data capture is required for 3D modelling, in most survey legislatures the surveyor is the technical person to measure and collate data before and after a project has been executed. So the final as built data is captured by the surveyor. Different equipments can be employed in this data collection depending on accuracy, cost, efficiency and technique employed for data acquisition. The methodology for data capture will depend on the 3D objects being collected (building, pipelines, tunnels, etc.), hence the method of data capturing may be different (Aien et. al., 2011). Traditional land surveying, aerial photogrammetry and laser scanning are the

most used methods to capture the data required for cadastre. Traditional land surveying is the oldest method for data capturing in the surveying field. Equipment's such as total stations, EDM (electronic distance measurement) are the most used devices in this field. Traditional land surveying compared to photogrammetry and laser scanning method is far cheaper but not precise as laser scanning and not as fast as photogrammetry for a large area. Surveyor's capture 3D in various formats such as slope distance, horizontal distance, vertical distance, the whole circle bearing and three dimensional coordinates, the representation of such information differs from one region to another. Also accuracy requirements may be different. The representation of 3D data using the vector approach is considered in this research.

#### 4. THE UNIFIED SPATIAL MODEL

The unified concept is based on tetrahedral meshes which can be degenerated to some 3D basic volumes such as the cube and other regular or irregular shapes. An enhanced 3D tetrahedral model (3DTM) is proposed, with the solid being formed by tetrahedrons or polyhedrons. This presents a solid and surface composed of tetrahedrons, a line is composed of segments and point consists of nodes. The unified spatial data model is shown in Figure 1.

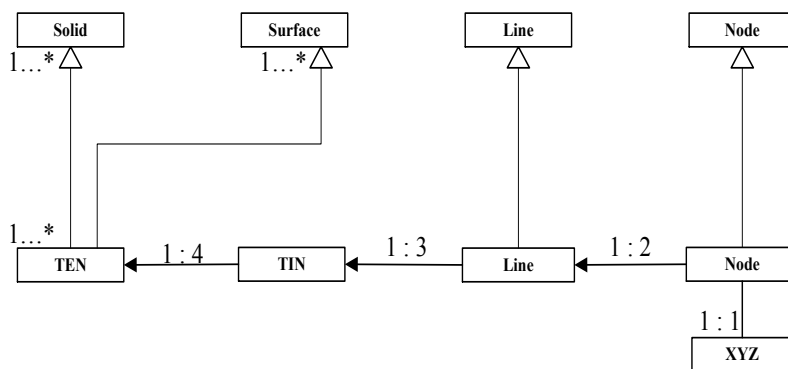

Figure 1. 3D Tetrahedralized Model (3DTM)

Nodes are formed by geographic coordinates XYZ which can form point features such as lamp posts, fire hydrant features and are part of the city furniture. Two nodes form the line or segment and can be expressed as a beginning node and an ending node. Three of such lines or segments will become part of the edge of the TIN surface. TIN surfaces will have edges or lines which will be shared and create the shared sub feature level (Pilouk, 1996) for a multi-theme model. The concept of implicit geometry and the merits of this geometry is well explained by OGC (2012) is used to form the nodes with appropriate identifiers, the line identifier will have a beginning node and an ending node with the topological relationship of *is on*, *is in*, point and solid, line and solid, line and surface, point and surface being used to form the relationship for the unified model. The 3DTM is formed by four nodes, six lines and four triangles, to form solids for both the surface and subsurface. The model is significant due

to the fact that it can be used to model regular and irregular objects and can thus represent features above, on and below the earth surface. Using the cube as the basic feature for volume objects, the cube can be decomposed to six regular tetrahedrons at the geometry level. The topological relationship is given by the adjacency of spatial objects. The logical model is presented in Figure 2.

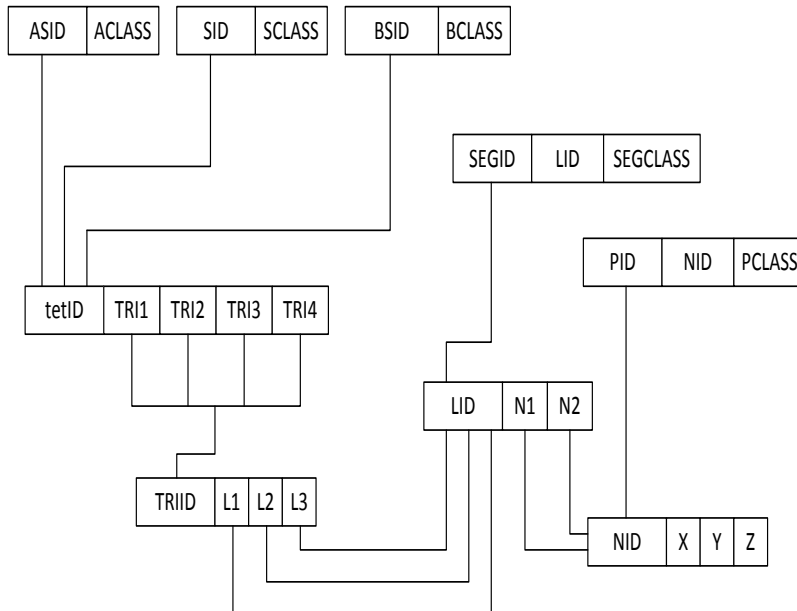

Figure 2. The Logical model

The classes for the various entities or features will then be connected or joined to the attributes to complete the database structure of the model. The above class (AClass) and surface class (SClass) and the below class (BClass) are all connected to the tetrahedron identifier (tetID) to form the unified spatial data model, topology is maintained between the faces.

Emgard and Zlatanova (2008) presented conceptual models for an integrated model within CityGML, and presented the terrain intersection curve (TIC) within that framework. This paper is advocating for a stand-alone platform which uses the tetrahedron as the solid for the unified spatial data model for the integration of the above, on and below 3D spatial objects. 3D city objects have underground facilities such as storage, tunnels, cavities, underground rail systems and car parks, knowledge about these man-made objects are required for 3D cadastre. From the concepts presented, the requirement for the unified spatial data model is to construct a 3D geometry capable of representing regular objects (such as buildings) and irregular objects (geological body, a spaghetti tunnel or transportation network or mine underground workings). The unified spatial data model should have sound or established mathematical background (counter clockwise algebraic topology in relation to simplexes or clockwise algebraic topology in relation to complexes). Also another requirement for the unified spatial data model is the support for topology, this must indicate the relationships between geometric objects, consistency constraints must be indicated and directional adjacencies such as beside, above and below highlighted..



2D GIS are well expressed and clear on topology as it clearly demonstrates the properties of connection, adjacency and containment. This expresses knowledge using the geometric properties of node, arc or line or edge and area or polygon. Research on 3D topology is still in the implementation stage as the topology between volumetric geometries is still not clear. Spatial database management systems such as Oracle Spatial 11g, PostgreGIS and Bentley have been used to implement some topology for specific applications. The spatial data model with its corresponding data structure is the core for 3D GIS software development. 3D topology model is in analysing 3D spatial phenomenon in the real world due to the spatial relations between each object. However the topology of 3D spatial objects is more difficult to analyse than 2D topology due to the complexity of 3D geometry. Therefore the implementation of topological operators in 3D spatial DBMS is more difficult than spatial DBMS for 2D spatial objects due to geometric complexity (Kim et. al., 2008).

Current researches focus on the implementation model and storage using 3D geometry in terms of 3D topological relations i.e. disjoint, meet, Equal, inside, contains, covers, coverby and overlap (Egenhofer and Sharma, 1993) for 3D spatial analysis. 3D topological operations cover the relationship of 4-intersection model (8 kinds of relations), this could be extended to 9-intersection model. A boundary representation (b-rep) model defines spatial objects by their bounding elements e.g. planar faces. Nodes and edges are defined by intersection of the bounding planes. B-rep model has been described as the model which constitutes the most popular model to store 3D topological data.

3D GIS analysis could also be implemented for 3D data type and functions. Although the theoretical number of the 9-intersection model is  $2^9$  i.e. 512 relationships, only a small number of these can be seen in reality (Zlatanova, 2000; Kurata, 2010).

Topology for some 3D data models can be divided into three groups:

- Surface and above surface (geographical) model  
The n-tuple model (Pigot, 1992) had the advantage of topological expression and easy maintenance because it is based on n-manifold model. OO3D model (Shi et. al., 2003) based on object oriented modelling had little 3D spatial analysis function but indistinct topology.
- Below surface (Geological) model, generalised tri-prism (GTP) model (Wu and Shi, 2004) had topology completely and used for 3D expression of geology based on drill hole data, but this model is difficult to visualize complex geological object.
- Unified (Integrated) model  
TIN + Octree data model (Shi, 1996), topology and query is easy, however if the TIN needs to be changed the octree data changes.

The topological structure for the unified model uses the basic solid geometry for 3D TIN which is the tetrahedron and further enhanced by incorporating some volume and quality statistics within a graphical user interface. This concept is adopted for the following reasons: It is possible to represent regular and irregular objects, the model is mathematically sound with topology being established geometrically by avoiding repetition of data, the condition of no gaps or overlaps are satisfied. The topology for the tetrahedron using the b-rep approach is shown in Figure 3.

/

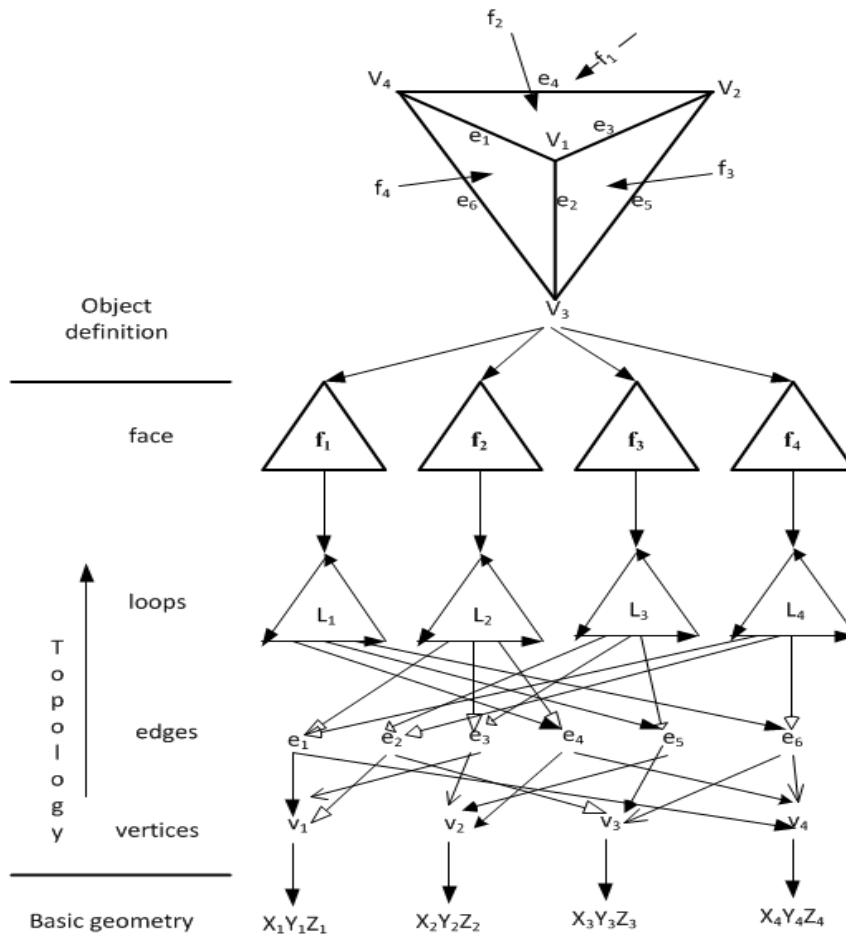

Figure 3. Topological structure for 3DTM

Spatial objects can be represented by boundary elements such as vertices, edges and face, with topology being introduced by the concept of adjacency. The concept of directional adjacency is employed to depict topological relations *above*, *beside* and *below* for the unified model. The Boundary representation forms objects such as edge, face and volume using the node as the geometric primitive. The concept is significant and has been explored in a hybridised form in most spatial data models. An attempt is made to represent the 3DTM as a unified spatial data model for 3D modelling for all objects above, on and below the city space for 3D spatial modelling. Section 5 presents the implementation for this research.

## 5. EXEMPLIFICATION

This research implements the unified spatial data model using Microsoft Visual C++ version 2008 programming software was used in conjunction with OpenGL and Qt libraries to create a prototype for the unified model. Implicit data using the boundary representation (b-rep) was

used to create a tetrahedral wireframe, which is then degenerated to form the basic volume, within a graphical user interface (GUI) capable of displaying the data structure and the attributes. The integrity of the tetrahedrons formed are checked using a quality check, the volume and centre of mass of the basic volume spaces determined (Duncan and Abdul Rahman, 2013), statistical inferences in relation to the quality of the tetrahedron are then computed.

Implicit geometry is used to form the nodes with appropriate identifiers, the line identifier will have a beginning node and an ending node with the topological relationship of is on, is in, point and solid, line and solid, line and surface, point and surface being used to form the relationship for the unified model. The tetrahedron is formed by four nodes, six lines and four triangles, to form solids for both the surface and subsurface. Six regular tetrahedrons form the basic cube which is the basic volume primitive in 3D GIS. Figure 4 shows the algorithm generated for this research.

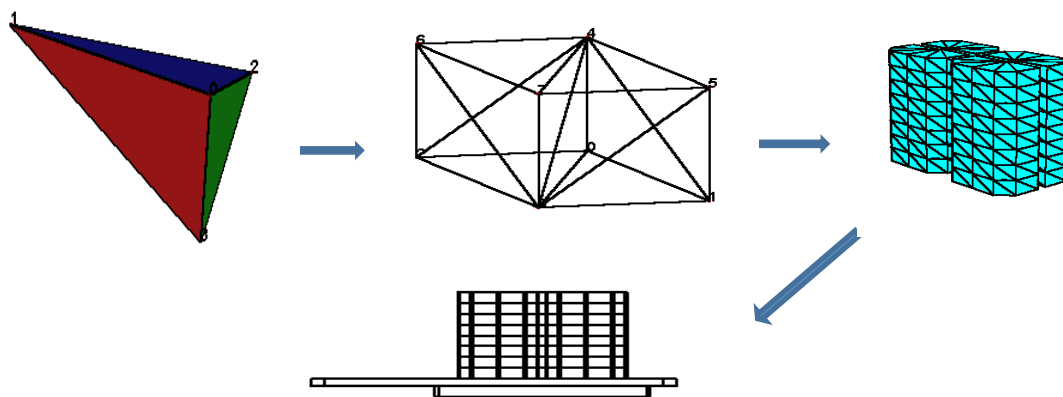

Figure 4. Tetrahedral mesh degenerated to 3D volume spaces

Figure 4 is the tetrahedral mesh for a twin eight story building which has been degenerated to simple blocks showing above, on and below surface man-made objects. Figure 5 is the graphics user interface (GUI) showing the basic geometry cube created from the tetrahedron with the volume and centre of mass computed, the volume is significant as it shows the 3D space occupied and the centre of mass of the cube used to enhance navigation within the block or described the block in an attribute database. In this research, indoor navigation has not been explored. Figure 5. Tetrahedral mesh for a building block degenerated to simplified unified block.

/

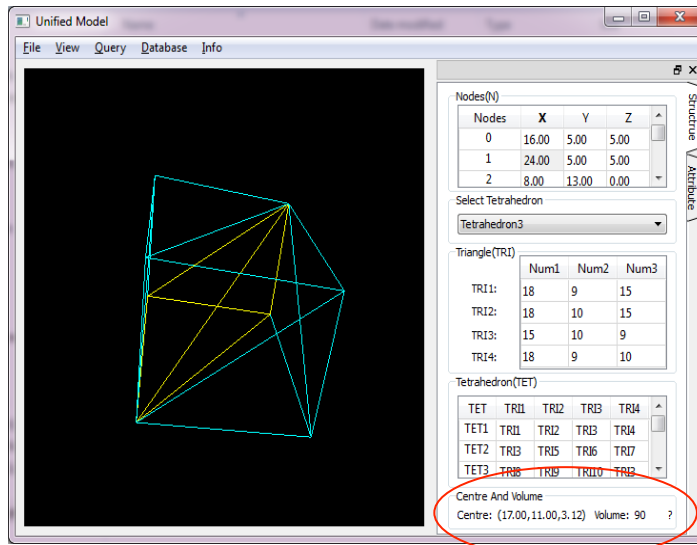

Figure 5. 3D TIN for volume parcels

Figure 6 shows a twin two eight storey building with subsurface man-made construction for parking. The graphical part is on the left with the semantic information on the right of the GUI showing a queried part. This concept can be extended for any multilevels.

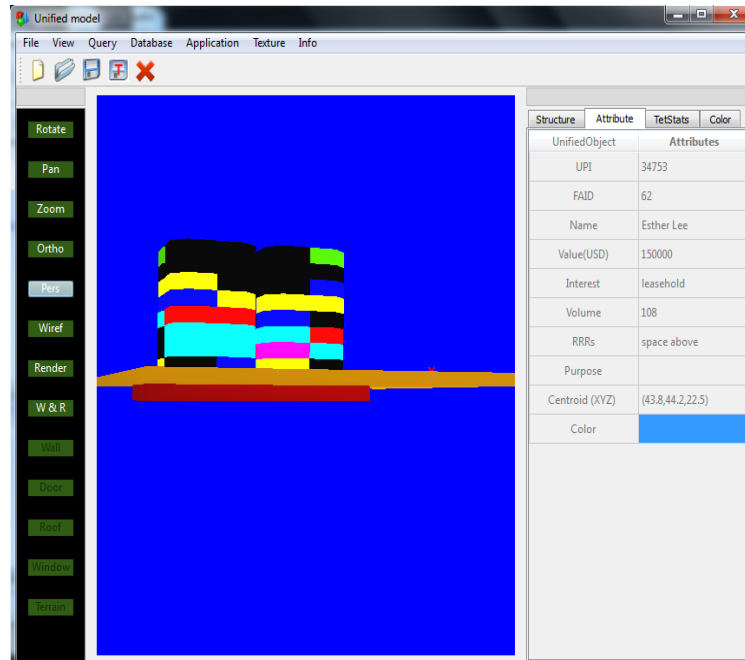

Figure 6. Application for 3D cadastre.

Texturing is the technique of increasing the Level of Realism (LoR) of 3D objects which among others include pictometry in the capture of appropriate images for the various components of a building such as window, door, and roof types to increase LoR. In this research, texturing using a hybridised rendering tool was used. This uses the colour code Red, Green and Blue (RGB) and images of windows and doors to fit a specific window and door size. This is a complex cadastral problem as it raises questions such as who owns the flats above the road. Who owns the land parcel under the road? What are the tax liabilities of these owners? What is the size of cavities or tunnels created or occupied beneath the surface? What are their liabilities? The unified spatial data model can provide answers to such queries. Figure 7 a textured block for 3D cadastre.

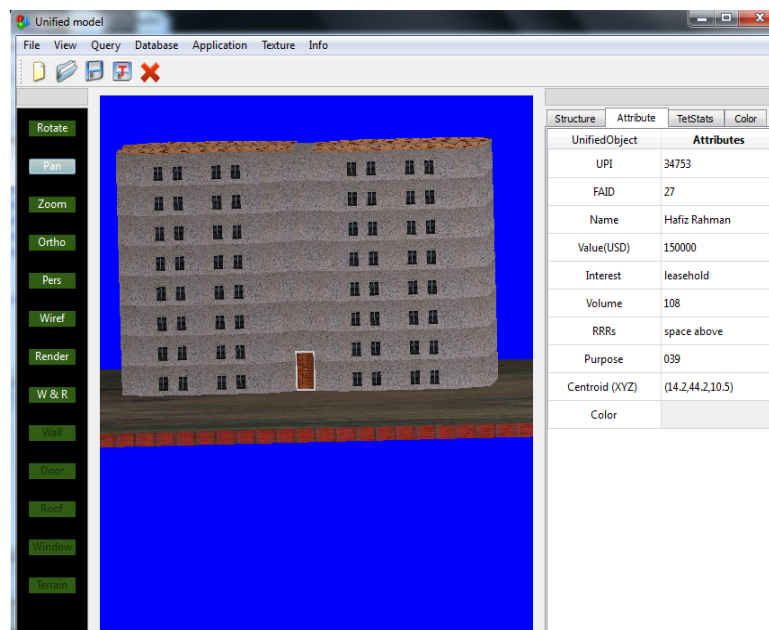

Figure 7. A Textured Block for 3D Cadastre

## 6. CONCLUDING REMARKS

This research has provided a geometric-topological framework for the depiction of volume parcels above, on or below the surface, this will improve ownership problems of flats, complex buildings and below ground spaces at most city centres. The detailed concepts will also serve as a framework which can be adopted by any country to improve its land databank. This can then be recommended as an input to improve the concept of the Land Administration Domain Model (LADM).

/

The 3DTM is an enhanced tetrahedralization model, it can represent features that are regular and irregular. The concept for a new unified model can integrate above surface objects and below surface geology and man-made objects based on tetrahedrons is possible. Research to integrate 3D GIS with Building Information models (BIM) must be intensified to help in the realisation of 3D GIS. The algorithm for the unified model if adopted will find useful applications in 3D Cadastre. Indoor navigation is the next phase for this research.

## ACKNOWLEDGEMENTS

The Authors wish to acknowledge the support of the 3D GIS research group, Faculty of Geoinformation and Real Estate, Universiti Teknologi Malaysia and the Association of Authorised Licensed Surveyors, Malaysia.

## REFERENCES

Abdul-Rahman, A. and Pilouk, M, (2008), *Spatial Data Modelling for 3D GIS*, published by Springer Berlin-Heidelberg, New York, 289pp.

Abdul Rahman. Alias, Hua, Teng Hua and Oosterom. Peter, Van (2011), Embedding 3D into Multipurpose cadastre. FIG working week, Marakech, 18-22 May, 2011.

Abdul-Rahman, A. and J. E. Stoter, A.F. Nordin, (2005), *Towards 3D Cadaster in Malaysia*. International Symposium and Exhibition on Geoinformation (ISG 2005). Penang, Malaysia.

Abdul Rahman, A., Van Oosterom, P. Hua, T. C. Sharkawi, K. H., Duncan, E. E., Azri, N. and Hassan, I. H. (2012), 3D Modelling for Multipurpose Cadastre 3rd International Workshop on 3D Cadastres: Developments and Practices 25-26 October 2012, Shenzhen, China, pp 185 -202.

Abdul-Rahman, A. (2000), The Design and Implementation of a Two and Three dimensional Triangular Network based GIS, PhD Thesis, University of Glasgow, U. K., 204pp.

Aien, A., Kalantari, M., Rajabifard, A., Williamson,, I. P., and Bennet, R. (2011), Advanced Principles of 3D Cadastral Data Modelling. Paper presented at the 2<sup>nd</sup> International Workshop on 3D Cadastres Proceeding, Delft, The Netherlands.

/

Arko-Adjei, Anthony, Jitske De Jong, Jaap Zevenbergen and Arbind Tuladhar. (2010), Customary Tenure Institutions and Good Governance. 20pp.  
[http://www.fig.net/pub/monthly\\_articles/september\\_2010/september\\_2010\\_arkoadjei\\_et\\_al.pdf](http://www.fig.net/pub/monthly_articles/september_2010/september_2010_arkoadjei_et_al.pdf) Accessed on: 6/10/10.

Apel, M. (2006), From **3D** Geomodelling Systems Towards **3D** Geoscience Information Systems: Data Model, Query Functionality, And Data Management. *Computers & Geosciences*, v. 32, iss. 2, pp. 222-229.

Astrand, L., (2010). Experiences of 3D Cadastre in Are, Sweden-Implementing a new tool for the property market. FIG Working Week 2008-Integrating Generations. Stockholm, Sweden. 14-19 June 2012, 17pp.

Breunig, M. and Zlatanova, S. (2006), *3D Geo-DBMS*. In Zlatanova, S. And Prosperi, D. (eds.), *Large-scale 3D Data Integration-Challenges and Opportunities*: 87-115. London: Taylor and Francis.

Breunig, M., Bode, T. and Cremers, A., (1994), Implementation of Elementary Geometric Database Operations for a 3D GIS. In: Proc. Of the 6<sup>th</sup> Int. Symp. On Spatial Data Handling.

Breunig, M., Cremers, A., Muller, W. and Siebeck, J., (2001), New Methods for Topological Clustering and Spatial Access in Object-oriented 3D databases. In: Proc. Of the 9<sup>th</sup> ACM Int. Symp. On Advances in Geographic Information Systems.

Coors, V., (2003), 3D-GIS in Networking Environments, Computer, Environments and Urban Systems, Vol. 27/4, Special Issue 3D Cadastre, pp 345 – 357.

Dale, P. F. and Mclaughlin, J. D. (1988), *Land Information Management*. Clarendon Press. Oxford. England. 182pp.

Duncan, E. E. and Abdul Rahman, A. (2013), A Unified 3D Cadastre Data Model – A Geometric Approach, GIS Ostrava 2013, Geoinformation for City Transformation, Jan 21-23. 2013, Ostrava, 15pp.

Ericsson, A. (1995), *The Cadastral System in Sweden*. 7pp.  
[http://www.geom.unimelb.edu.au/fig7/Delft\\_seminar\\_95/paper6.html](http://www.geom.unimelb.edu.au/fig7/Delft_seminar_95/paper6.html) Accessed on 22/10/10.

Ericsson, A. (2008). What makes the Swedish cadastral system so special and successful? Pp 1-11. [http://www.fig.net/pub/monthly\\_articles/june\\_2008](http://www.fig.net/pub/monthly_articles/june_2008) Accessed 4/11/10.

ESRI, (2005), *GIS for Cadastral Management*, published by ESRI, USA. 20pp  
Emgard, L. and S. Zlatanova, 2008, Design Of An Integrated **3D** Information Model, in Coors, Rumor, Fendel and Zlatanova (eds.) *Urban and Regional data Management, UDMS Annual 2008*, Taylor and Francis Group, London, pp. 143-156.

/

Foley, J., van Dam, A., Feiner, S., and Hughes, J., (1995): Computer Graphics: Principles and Practice. Addison Wesley, 2nd Ed.

Gold, C., (2008), Chapter 25 Working Group III-Modelling-Position paper on Modelling 3D Geo-Information. In *Advances in 3D Geoinformation Systems*, Eds. P. Van Oosterom, S. Zlatanova, F. Penninga, E. Fendel published by Springer Berlin-Heidelberg, New York, pp 429-435.

ISO/CD 19152, (2009). Community Draft of TC211 geographic information e land administration domain model. [http://www.iso.org/iso/catalogue\\_detail.htm?csnumber/451206](http://www.iso.org/iso/catalogue_detail.htm?csnumber/451206) (accessed 8.10.10).

Kolbe, T. H. (2009), Representing and Exchanging 3D City Models with CityGML, Lee, J., Zlatanova, S. (Eds), 3D Geoinformation Sciences, Springer Verlag, Berlin Heidelberg.

Kurata, Y. (2010). An Overview of the Research on Topological Relations and Future issues in GIScience theory and Applications of GIS, 18(2), 41-51.

Ledoux, H. and Gold, C. M. (2008), Modelling Three-dimensional Geoscientific Fields with Voronoi Diagram and its Dual. *Int. J. of Geographical Information Science*. Vol. 22. Nos 4 – 5, April – May 2008, 547 – 574.

Lemmen, C., van Oosterom, P., Uitermark, H., Thompson, R. and Hespanha, J.P. (2009). Transforming the Land Administration Domain Model (LADM) into an ISO standard (ISO19152). FIG Working Week 2009. Eilat, Israel. [http://www.gdmc.nl/publications/2009/LADM\\_to\\_ISO\\_Standard.pdf](http://www.gdmc.nl/publications/2009/LADM_to_ISO_Standard.pdf).

Lemmen, C. (2012). A Domain Model for Land Administration, PhD Thesis, ITC dissertation number 210. ISBN 978 90 6132 3365. 234pp.

Molenaar, M. (1990), A Formal Data Structure for 3D Vector Maps, *Proceedings of EGIS'90* Vol.2, Amsterdam, The Netherlands, pp 770 – 781.

OGC, (2012). Open Geospatial Consortium, CityGML Encoding Standard Version 2.0, OGC Doc No 12=019, 04-04-2012, Eds: Gerhard Gröger, Thomas H. Kolbe, Claus Nagel, Karl-Heinz Häfele, 326pp.

OGC, (2013). Open Geospatial Consortium, The OGC and GeoSciML 4.0 Standards Working Group. <http://www.opengeospatial.org/pressroom/pressreleases/1794>, Accessed 12/3/2013.

Penninga, F. and Oosterom, P. J. M. (2008), A Simplicial Complex-Based DBMS Approach to 3D Topographic Data Modelling, *Int J. Geographic Information Science*, Vol. 22. Nos 6-7, June-July 2008, 751-779.



/

Penninga, F., van Oosterom, P. and Kazar, B., (2006), A Tetrahedronized Irregular Network Based DBMS Approach for 3D Topographic Data Modelling. *Progress in Spatial Data Handling, 12<sup>th</sup> International Symposium on Spatial Data Handling*, 581 – 598 Springer Berlin Heidelberg 2006.

Pigot, S., (1992), A Topological Model for a 3-D Spatial Information Systems, Proc. 10<sup>th</sup> International Symposium on Computer Assisted Cartography (AUTOCARTO 10), Technical Papers, ACSM-ASPRS, Annual Convention, Vol. 6, Baltimore, Maryland, USA, pp 369-391.

Pilouk, M., (1996), Integrated Modelling for 3D GIS. PhD dissertation, ITC Publications No 40, The Netherlands, 200pp,

Shi, W. Z., (1996), A Hybrid Model For 3D GIS. *Geoinformatics* **1**, pp.400-409.

Shi, W. Z., (2000), Development of A Hybrid Model For Three-Dimensional GIS. *Geo-Spatial Information Science* **3** 2, pp.6-12.

Stoter, J. E. (2004), *3D Cadastre*. Ph.D. Thesis. Delft University of Technology, Delft, the Netherlands.

Skrubbeltrang, Jørgen (2004), The Danish Multipurpose cadastre- Experiences so far [http://www.fig.net/pub/athens/papers/ts01/ts01\\_4\\_skrubbeltrang.pdf](http://www.fig.net/pub/athens/papers/ts01/ts01_4_skrubbeltrang.pdf). pp1-15. Accessed: 5/10/10. Office of the Surveyor-General New Zealand, Land Information [1999].

Sutherland, M., Ng'ang'a, S., Nichols, S. and Cockburn, S. (2001), Toward A Multidimensional Marine Cadastre In Support Of Good Ocean Governance – New Spatial Information Management Tools and Their Role in Natural Resource Management, International Conference on Spatial Information for Sustainable Development, Nairobi, Kenya, 2-5 October 2001

Wang, Y. (2006), 3D GIS Spatial Modelling for City Surface and Subsurface Integration, published by IEEE, pp 1511 – 1518.

Wu, L and Shi, W. (2004), GTP-Based Integral Real 3D Spatial Model for Engineering Excavation GIS (E<sup>2</sup> GIS), *Geo-spatial Information Science (Quarterly)* **7**(3), pp 123 – 128.

Wu, L. X., Shi, W. Z. and Christopher, G. M., (2003), Spatial Modelling Technologies for 3D GIS and 3D GMS. *Geography and Geo-information Sciences* **19** 1, pp.5-11.

Zhou, I., Lu, G., Sheng, Y., Xu. H., and Wang, H., (2008), A 3d GIS's Spatial Data Model Based on Cell Complex. *The International Archives of the Photogrammetry, Remote Sensing and Spatial Information Sciences*. Vol. XXXVII Part B2, Beijing, pp 905 – 908.

Zlatanova, S., Abdul Rahman, A and Pilouk, M (2002), “3D GIS: Current Status and Perspectives” ISPRS Commission IV, WGIV/1, pp1-6.

/

Zlatanova, S., Abdul Rahman, A and Pilouk, M (2002), “3D GIS: Current Status and Perspectives” ISPRS Commission IV, WGIV/1, pp1-6.

Zlatanova, S. (2000), 3D GIS for Urban Development, PhD Thesis, ITC Dissertation Series No 69. The International Institute for Aerospace Survey and Earth Sciences, The Netherlands.

## **BIOGRAPHICAL NOTES**

**E. E. Duncan**, holds a MSc degree in Topographic Science (Surveying) from Glasgow University in the UK and BSc degree in Geodetic Engineering from the Kwame Nkrumah University of Science and Technology in Ghana. He is also a Professional member of the Ghana Institution of Surveyors (MGhIS) and a lecturer (On Study leave) at the University of Mines and Technology in Ghana. He is currently a PhD researcher with the 3D GIS research group of the Faculty of Geoinformation and Real Estate at the Universiti Teknologi Malaysia (UTM) in Malaysia. His current research interests include 3D spatial models for surface and subsurface objects.

Siew Chengxi Bernad, obtained a Bsc degree in Geoinformatics in 2009 from Universiti Teknologi Malaysia (UTM), Skudai, Johor. He is a professional programmer. He worked as an IT Manager in ABS Innovations Sdn Bhd and a Chief Technical Officer in Effisys Technology, Malaysia. He has been involved in developing various web and mobile applications. Currently, he is a PhD researcher with the 3D GIS Research Group in the Faculty of Geoinformation and Real Estate, UTM. His current research interests are in the area of distributed web environment for 3D GIS and compression techniques for 3D datasets.

## **CONTACTS**

Edward Eric DUNCAN and Bernad Chengxi SIEW  
University Technology Malaysia  
Faculty of Geoinformation and Real Estate, 81310,  
Skudai, Johor Bahru  
MALAYSIA  
Tel. +060177639038 / 06137490452  
Fax +(6)075566163  
Email: [edwduncan@yahoo.com](mailto:edwduncan@yahoo.com) / [ededward2@live.utm.my](mailto:ededward2@live.utm.my) and [siewster@gmail.com](mailto:siewster@gmail.com)  
Web site: [www.fght.utm.my](http://www.fght.utm.my)